

Adjustments

⚠ Warning!

Before driving, always make sure that the basic settings made by Öhlins are according to recommended Set-up Data. Read about adjustments and setting up in the Öhlins Owner's Manual before you make any adjustments. Contact an Öhlins dealer if you have any questions about setting up the shock absorber.

The standard preload is 4 mm, see fig③.

Set-up Data

Recommended set-up

Rebound setting

Track	0-7 clicks
Winding road	5-10 clicks
Street	10-20 clicks

Spring preload 4 mm

Shock absorber length 531 mm

Spring

Spec H200, ID65_103, 70 N/mm

The actual vehicle height

With both the preload and height adjustments in their standard positions, the vehicle is lowered approximately 20mm when compared to the original suspension. As the height adjuster is turned one rotation, the position moves 1.5 mm.

⚠ Warning!

The adjustment range is the standard position -15 to +6 mm.

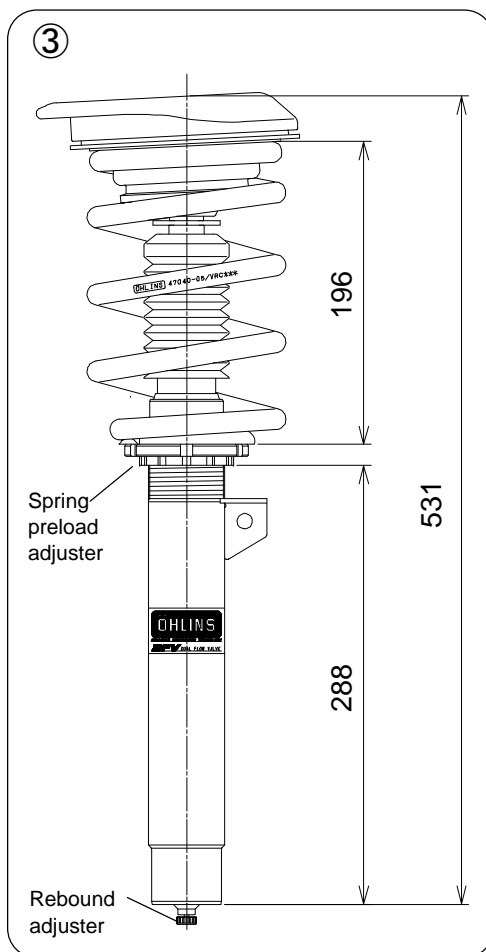

Before installing this product, check the contents of the kit. If anything is missing, please contact an Öhlins dealer.

Kit Contents	Pcs.
Shock absorber	2
Dust boot	2
Spring	2
Lock nut M14	2
Washer	2

USED FOR BOTH FRONT AND REAR

C-spanner 1	1
C-spanner 2	1
Öhlins sticker	1
Öhlins Owner's Manual	1

Please note that during storage and transportation, especially at high ambient temperature, some of the oil and grease used for assembling may leak and stain the packaging. This is in no way detrimental to the product, wipe off the excess oil/grease with a cloth.

⚠ Warning!

Before installing this product, read the Öhlins Owner's Manual. The shock absorber is an important part of your vehicle and will affect the stability.

© Öhlins products are subject to continuous improvement and development, therefore, although these instructions include the most up-to-date information available at the time of printing, minor updates may occur.

To find the latest information contact your Öhlins distributor. Please consult your Öhlins dealer if you have any questions regarding the contents in this document.

Part no. BMS MI30_1
Issued 2012-12-10



© Öhlins Racing AB. All rights reserved. Any reprinting or unauthorized use without the written permission of Öhlins Racing AB is prohibited.

Öhlins Racing AB



www.ohlins.com

Shock Absorber Kit for BMW M3 (E46)

BMS MI30 front Mounting Instructions



⚠ Warning!

It is advisable to have an Öhlins dealer install the shock absorber. When installing, read your Vehicle Service Manual.



1

Raise the vehicle and put it on jack stands.

⚠ Warning!

Ensure that it is securely supported.

2

Remove the front wheels.

3

Loosen the bolts for the lower strut attachments.

⚠ Caution!

Support the wheel hubs in an appropriate way on each side of the vehicle so that the brake hoses can not be damaged.

4

Loosen the upper attachments. Remove the original struts from the car.

5

Cut the dust boot 62 mm from the lower end with a pair of scissors according to fig②.

6

Tighten the lower spring seat and the lock ring to 50 - 60 Nm. Fit the dust boot, the spring, the washer, the original top mount, the original washer, and the lock nut M14 to the strut according to fig ①. Tighten the lock nut to 35 - 40 Nm.

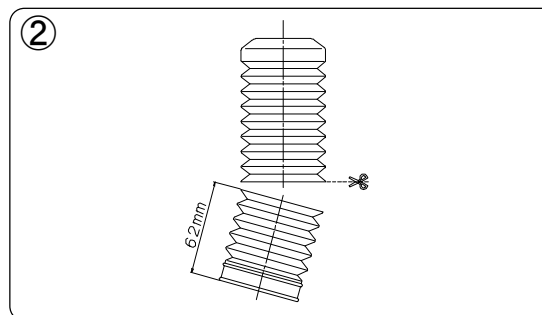
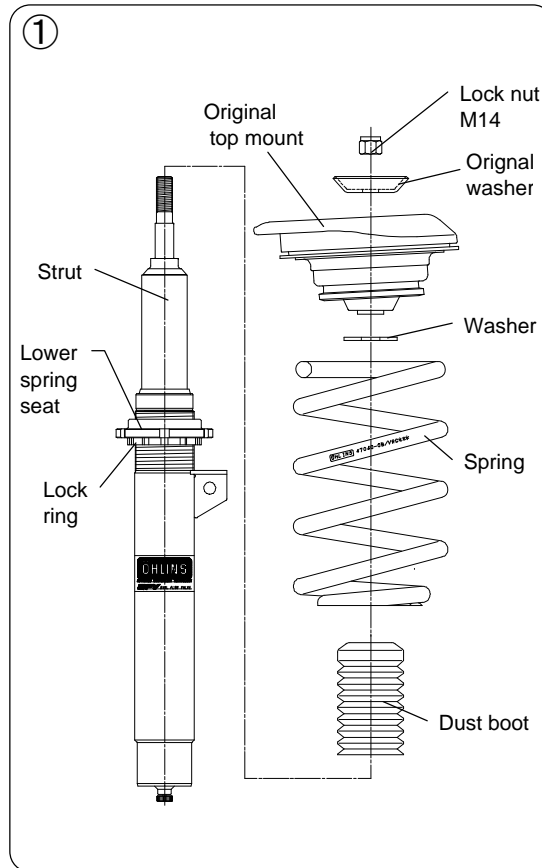

7

Install the Öhlins McPherson struts on the vehicle according to fig③. Fit the stabilizer link.

8

Fasten the upper attachments.

👁 Note!

When tightening the top mount nut, the shock absorber shaft must be held in position with a 6 mm Allen key.

9

Raise the wheel hub with a jack to remove the freeplay of the lower strut attachment bolts before tightening them.

👁 Note!

Make sure that all bolts are tightened to the correct torque and that nothing fouls or restricts movement of the strut when it is being fully compressed or extended. Test this over the whole steering range from lock to lock.

10

Make sure that all removed parts are reinstalled in the same way as they were before the installation of the Öhlins shock absorber.

Adjustments

⚠ Warning!

Before driving, always make sure that the basic settings made by Öhlins are according to recommended Set-up Data. Read about adjustments and setting up in the Öhlins Owner's Manual before you make any adjustments. Contact an Öhlins dealer if you have any questions about setting up the shock absorber.

Set-up Data

Recommended set-up

Rebound setting

Track	0-7 clicks
Winding road	5-10 clicks
Street	10-20 clicks

Spring preload adjuster height	13 mm
Shock absorber length	535 mm

Spring

Spec H130, ID52-65, 110 N/mm

The actual vehicle height

With both the preload and height adjustments in their standard positions, the vehicle is lowered approximately 20 mm when compared to the original suspension. As the height adjuster is turned one rotation, the position moves 1.5 mm.

⚠ Warning!

The adjustment range is the standard position -10 to +15 mm. If the bracket is moved outside the adjustment range, it may come loose.

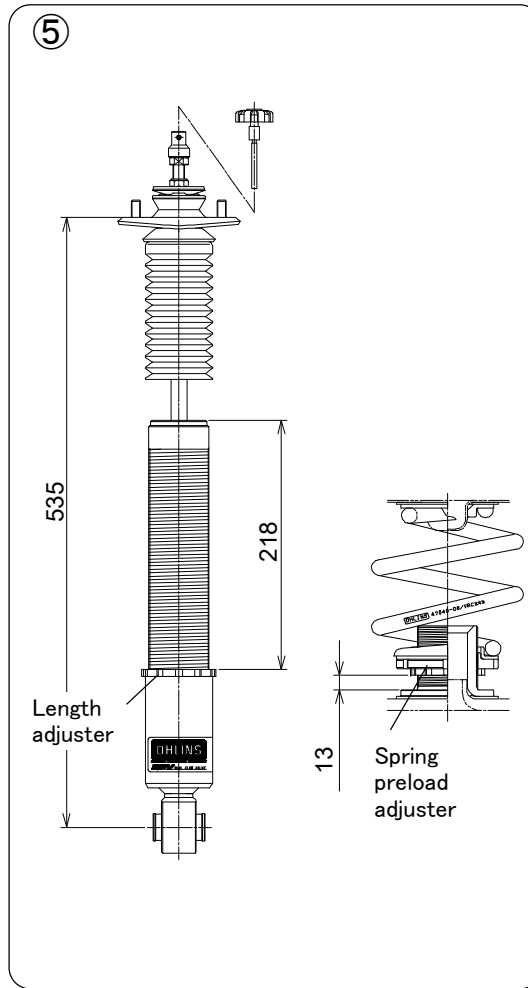

Before installing this product, check the contents of the kit. If anything is missing, please contact an Öhlins dealer.

Kit Contents	Pcs.
Shock absorber	2
Spacer	2
Lock nut M10	2
Screw (M4)	2
Handle	2
Control wire	2
Allen key	1
Bushing spacer	2
Dust boot	2
Spring	2
Spring preload adjuster	2
Rubber seat	4
Upper plastic seat	2
Lower plastic seat	2
MOUNTED ON SHOCK ABSORBER	
Adjuster	2
USED FOR BOTH FRONT AND REAR	
C-spanner 1	1
C-spanner 2	1
Öhlins sticker	1
Öhlins Owner's Manual	1

Please note that during storage and transportation, especially at high ambient temperature, some of the oil and grease used for assembling may leak and stain the packaging. This is in no way detrimental to the product, wipe off the excess oil/grease with a cloth.

⚠ Warning!

Before installing this product, read the Öhlins Owner's Manual. The shock absorber is an important part of your vehicle and will affect the stability.

Öhlins products are subject to continuous improvement and development, therefore, although these instructions include the most up-to-date information available at the time of printing, minor updates may occur.

To find the latest information contact your Öhlins distributor. Please consult your Öhlins dealer if you have any questions regarding the contents in this document.

Part no. BMSMI30_1
Issued 2012-12-10



Shock Absorber Kit for BMW M3 (E46)

BMS MI30 rear

Mounting Instructions

© Öhlins Racing AB. All rights reserved. Any reprinting or unauthorized use without the written permission of Öhlins Racing AB is prohibited.

Öhlins Racing AB



www.ohlins.com



How to install

⚠ Warning!

It is advisable to have an Öhlins dealer install the shock absorber.
When installing, read your Vehicle Service Manual.



1

Raise the vehicle and put it on jack stands.

⚠ Warning!

Ensure that it is securely supported.

2

Remove the rear wheels.

3

Remove the lower and the upper attachments and remove the original shock absorbers.

4

Remove the spring.

5

Set the spring seat of the spring preload adjuster to the position according to fig 5.

6

Install the Öhlins spring and the spring preload adjuster on the vehicle according to fig 3.

7

Cut the dust boot 32 mm from the lower end with a pair of scissors according to fig 2.

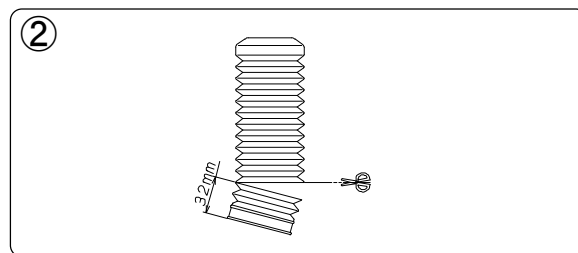
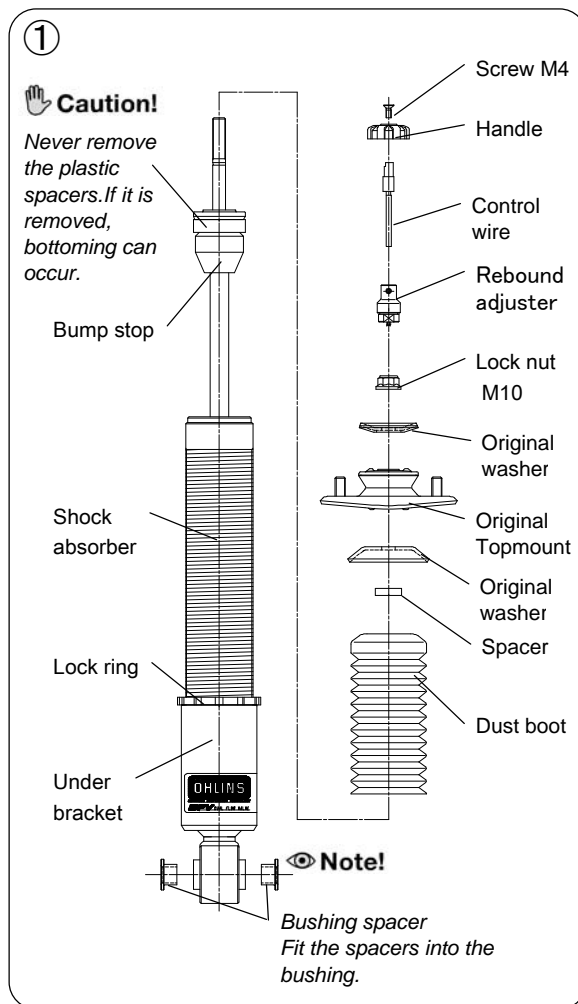

8

Fit the bushing spacers, the dust boot, the spacer, the original washer, the original topmount, the original washer, the lock nut and the adjuster according to fig 1. Tighten the lock nut to 30 Nm.

👁 Note!

When tightening the lock nut, the shock absorber shaft must be held in position with a 5 mm Allen key.

9

Install the Öhlins shock absorbers on the vehicle.

10

Make sure that all removed parts are reinstalled in the same way as they were before the installation of the Öhlins shock absorber.

👁 Note!

Make sure that all bolts are tightened to the correct torque and that nothing fouls or restricts movement of the shock absorber when it is being fully compressed or extended.

11

Sub-assemble the wire. (Fasten the handle by tightening the M4 screw.) As shown in fig 4, insert the wire through the Ø10 hole which is made in the side panel, and run it inside the panel. Insert the top end of the wire into the adjuster and fasten it with the supplied Allen key.

How to install

