



Kit Contents	
Description	Pcs
Shock absorber	2
Dust boot	2
Spring	2
Lock nut	2
Spacer	2
Spring seat	2
<b>Mounted on shock absorber</b>	
Sleeve	1
<b>Used for both front and rear</b>	
C-spanner	2
Öhlins Sticker	1
Öhlins Owner's Manual	1

**👁 Note!**

Please note that there can be small differences between your product and the images in these instructions.

**👁 Note!**

Please note that during storage and transport, especially at high ambient temperature, some of the oil and grease used for assembly may leak and stain the packaging. This will not cause damage to the product, wipe off the excessive oil or grease with a cloth.

**👁 Note!**

Before you install this product, check the kit contents. If anything is missing, please contact an Öhlins dealer.

**⚠ Warning!**

Before you install this product, read the Öhlins Owner's manual. This product is an important part of the vehicle and the vehicle stability.

## Shock Absorber Kit for BMW 3-series (F30)

# **BMS MP00** front

## Mounting Instructions



# MOUNTING INSTRUCTIONS

## **⚠ Warning!**

*It is advisable to have an Öhlins dealer install the shock absorber.*

*When installing, read your Vehicle Service Manual.*

**1**

Raise the vehicle and put it on jack stands.

## **⚠ Warning!**

*Ensure that it is securely supported.*

**2**

Remove the front wheels.

**3**

Loosen the bolts for the lower strut attachments.

## **⚠ Caution!**

*Support the wheel hubs in an appropriate way on each side of the vehicle so that the brake hoses can not be damaged.*

**4**

Loosen the upper attachments. Remove the original struts from the car.

**5**

Cut the dust boot 62 mm from the lower end with a pair of scissors according to fig 5.

**6**

Tighten the lower spring seat and the lock nut to 50 - 60 Nm. Fit the dust boot, the spring, the upper spring seat, the spacer, the original top mount and the lock nut to the strut according to fig 6.

Tighten the top nut to 35 - 40 Nm.

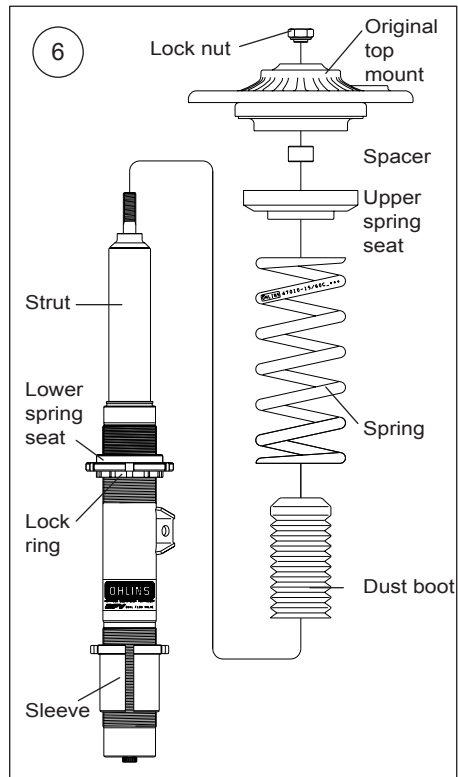
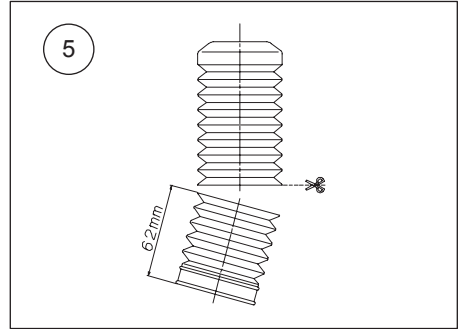

# MOUNTING INSTRUCTIONS

7

Install the Öhlins McPherson struts on the vehicle according to fig 7a.

Install the stabilizer link according to fig 7b.

8

Fasten the upper attachments.

**Note!**

*When tightening the top mount nut, the shock absorber shaft must be held in position with a 6 mm Allen key.*

9

Raise the wheel hub with a jack to remove the freeplay of the lower strut attachment bolts before tightening them.

**Note!**

*Make sure that all bolts are tightened to the correct torque and that nothing fouls or restricts movement of the strut when it is being fully compressed or extended. Test this over the whole steering range from lock to lock.*

10

Make sure that all removed parts are reinstalled in the same way as they were before the installation of the Öhlins shock absorber.

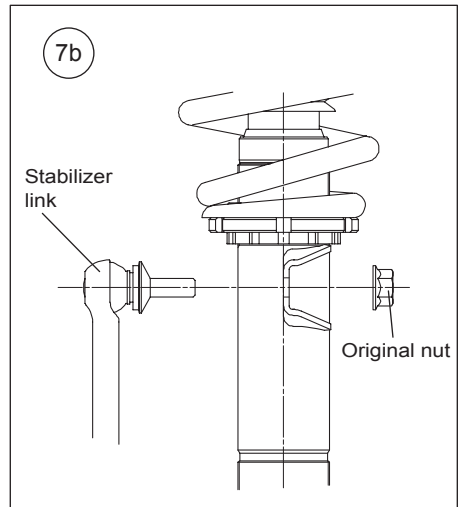
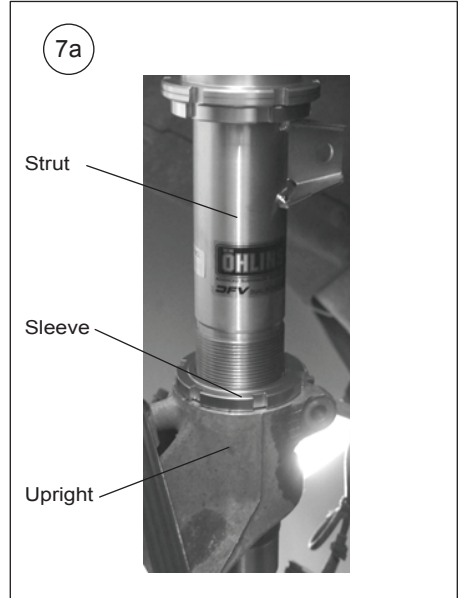

# ADJUSTMENTS

## ⚠ Warning!

Before driving, always make sure that the basic settings made by Öhlins are according to recommended Set-up Data. Read about adjustments and setting up in the Öhlins Owner's Manual before you make any adjustments. Contact an Öhlins dealer if you have any questions about setting up the shock absorber.

The standard preload is 5 mm, see figure.

## SETUP DATA

Click setting		
Track	0-7	clicks
Winding road	5-10	clicks
Street	10-20	clicks
Spring preload	5	mm
Shock absorber length	520	mm
<b>Spring</b>		
Spec: H200, ID65, 60 N/mm		

### The actual vehicle height

With both the preload and height adjustments in their standard positions, the vehicle is lowered approximately 20 mm when compared to the original suspension. As the height adjuster is turned one rotation, the position moves 1.5 mm.

## ⚠ Warning!

The adjustment range is the standard position -5/+15 mm. If the bracket is moved outside the adjustment range, it may come loose.

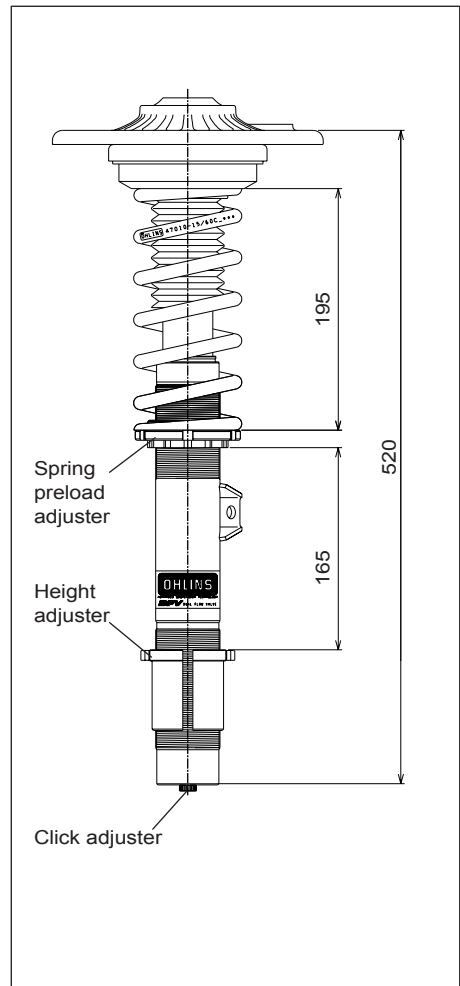

Öhlins products are subject to continuous improvement and development, therefore, although these instructions include the most up-to-date information available at the time of printing, minor updates may occur.

To find the latest information contact an Öhlins distributor. Please contact Öhlins if you have any questions regarding the contents in this document.

Part no. MI\_BMSMP00\_front\_1  
Issued 2015-06-03

© Öhlins Racing AB. All rights reserved. Any reprinting or unauthorized use without the written permission of Öhlins Racing AB is prohibited.

Öhlins Racing AB  
Box 722  
S-194 27 Upplands Väsby, Sweden  
Phone +46 8 590 025 00  
fax +46 8 590 025 80



[www.ohlins.com](http://www.ohlins.com)



Kit Contents	
Description	Pcs
Shock absorber	2
Lock nut M10	2
Bushing spacer	4
Dust boot	2
Spring	2
Spring reload adjuster	2
Rubber seat	2
Lower plastic seat	2
Tie-rod	4

**👁 Note!**

Please note that there can be small differences between your product and the images in these instructions.

**👁 Note!**

Please note that during storage and transport, especially at high ambient temperature, some of the oil and grease used for assembly may leak and stain the packaging. This will not cause damage to the product, wipe off the excessive oil or grease with a cloth.

**👁 Note!**

Before you install this product, check the kit contents. If anything is missing, please contact an Öhlins dealer.

**⚠ Warning!**

Before you install this product, read the Öhlins Owner's manual. This product is an important part of the vehicle and the vehicle stability.

## Shock Absorber Kit for BMW 3-series (F30)

# **BMS MP00<sub>rear</sub>**

## Mounting Instructions

# MOUNTING INSTRUCTIONS

## **⚠ Warning!**

*It is advisable to have an Öhlins dealer install the shock absorber. When installing, read your Vehicle Service Manual.*

**1**

Raise the vehicle and put it on jack stands.

## **⚠ Warning!**

*Ensure that it is securely supported.*

**2**

Remove the rear wheels.

**3**

Remove the lower and the upper attachments and remove the original shock absorbers.

**4**

Remove the spring.

**5**

Set the spring seat of the spring preload adjuster to the position according to fig 5.

**6**

Remove the OEM upper spring cup according to figure 6.

**7**

Install the Öhlins spring and the spring preload adjuster on the vehicle according to fig 7.

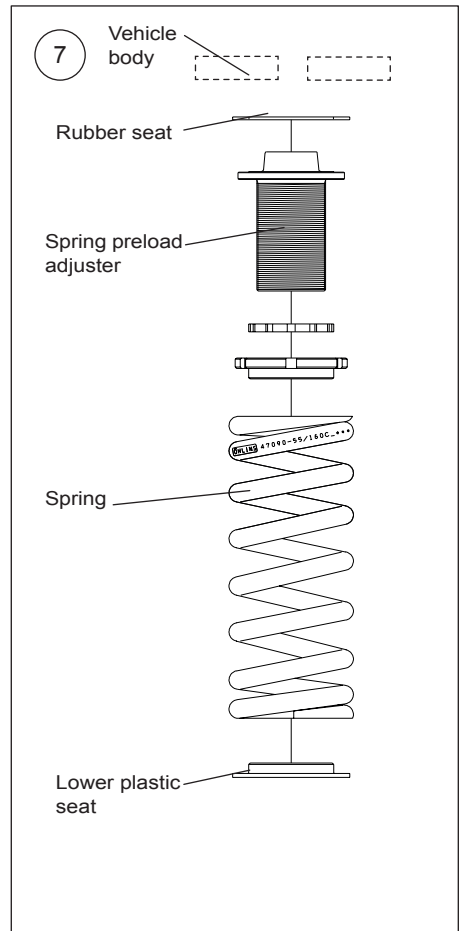
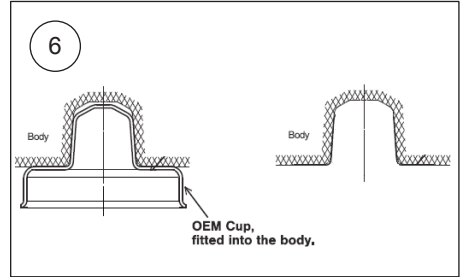

# MOUNTING INSTRUCTIONS

8

Tighten the lock ring to 50 - 60 Nm. Fit the bushing spacers, the dust boot, the original top mount and the lock nut according to fig 8. Tighten the lock nut to 30 Nm.

**Note!**

*When tightening the lock nut, the shock absorber shaft must be held in position with a 4 mm Allen key.*

9

Install the Öhlins shock absorbers on the vehicle.

10

Make sure that all removed parts are reinstalled in the same way as they were before the installation of the Öhlins shock absorber.

**Note!**

*Make sure that all bolts are tightened to the correct torque and that nothing fouls or restricts movement of the shock absorber when it is being fully compressed or extended*

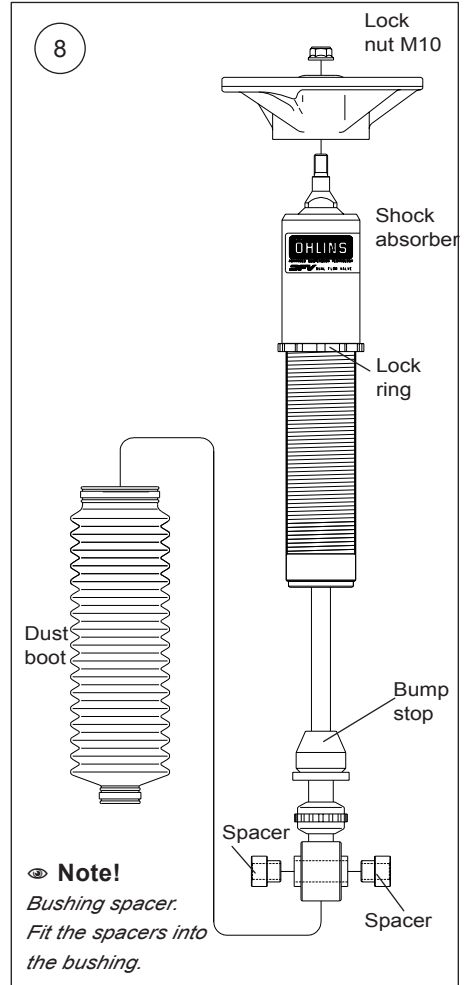

# ADJUSTMENTS

## **⚠ Warning!**

Before driving, always make sure that the basic settings made by Öhlins are according to recommended Set-up Data. Read about adjustments and setting up in the Öhlins Owner's Manual before you make any adjustments. Contact an Öhlins dealer if you have any questions about setting up the shock absorber.

# SETUP DATA

Recommended set-up		
Click setting		
Track	0-7	clicks
Winding road	5-10	clicks
Street	10-20	clicks
Spring preload position	22	mm
Shock absorber length	545	mm
<b>Spring</b>		
Spec: H230, ID65, 160 N/mm		

## Vehicle Height

With both the preload and height adjustments in their standard positions, the vehicle is lowered approximately 15 mm when compared to the original suspension. As the height adjuster is turned one rotation, the position moves 1.5 mm.

## **⚠ Warning!**

The adjustment range is the standard position  $\pm 15$  mm.

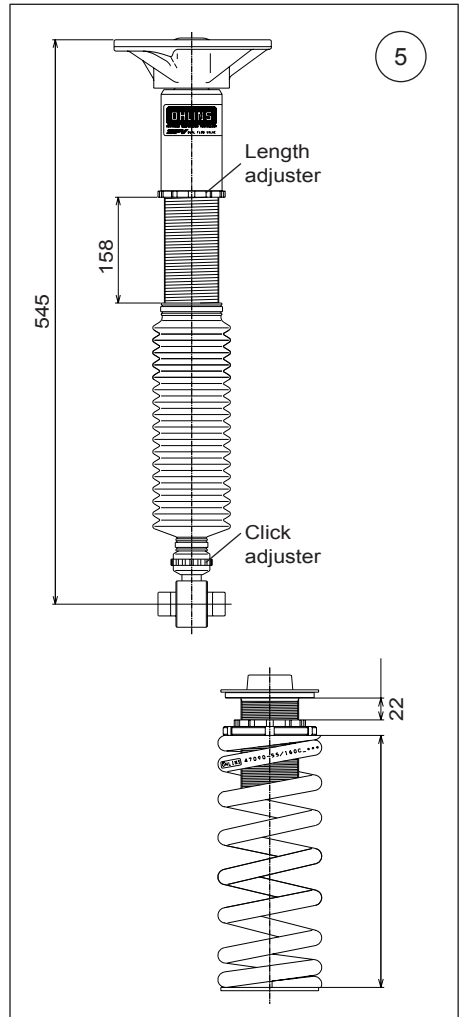

Öhlins products are subject to continuous improvement and development, therefore, although these instructions include the most up-to-date information available at the time of printing, minor updates may occur.

To find the latest information contact an Öhlins distributor. Please contact Öhlins if you have any questions regarding the contents in this document.

Part no. MI\_BMSMP00\_rear\_1  
Issued 2015-06-03

© Öhlins Racing AB. All rights reserved. Any reprinting or unauthorized use without the written permission of Öhlins Racing AB is prohibited.

Öhlins Racing AB  
Box 722  
S-194 27 Upplands Väsby, Sweden  
Phone +46 8 590 025 00  
fax +46 8 590 025 80



[www.ohlins.com](http://www.ohlins.com)