



Kit Contents

	Description	Part No	Pcs
1	Sleeve		2
2	Shock absorber	POS 5P80	2
3	Dust boot		2
4	Spring		2
5	Spacer		2
6	Upper spring seat		2
7	Lock nut M14		2
8	C-spanner	24639-03	1
9	C-spanner	24639-01	1
10	Öhlins sticker kit	10207-01	1
11	Öhlins emblem kit	10207-02	1
12	Öhlins Owners Manual		1

👁 Note!

Please note that there can be small differences between your product and the images in these instructions.

👁 Note!

Please note that during storage and transport, especially at high ambient temperature, some of the oil and grease used for assembly may leak and stain the packaging. This will not cause damage to the product, wipe off the excessive oil or grease with a cloth.

👁 Note!

Before you install this product, check the kit contents. If anything is missing, please contact an Öhlins dealer.

⚠ Warning!

Before you install this product, read the Öhlins Owner's manual. This product is an important part of the vehicle and the vehicle stability.

Shock absorber Kit for Porsche 981 Cayman

POS MP80 front

Mounting Instructions



MOUNTING INSTRUCTIONS

⚠ Warning!

We strongly recommend to let an Öhlins dealer install this product.

⚠ Warning!

If you work with a lifted vehicle, make sure that it is safely supported to prevent it from tipping over.

👁 Note!

When you work with this product, see the vehicle service manual for vehicle specific procedures and important data.

👁 Note!

Before you install this product clean the vehicle.

1

Raise the vehicle and put it on jack stands.

2

Remove the front wheels.

3

Loosen the bolts for the lower strut attachments.

👉 Caution!

Support the wheel hubs in an appropriate way on each side of the vehicle so that the brake hoses can not be damaged.

4

Loosen the upper attachments. Remove the original struts from the car.

5

Cut the dust boot 62 mm from the lower end with a pair of scissors according to fig 2.

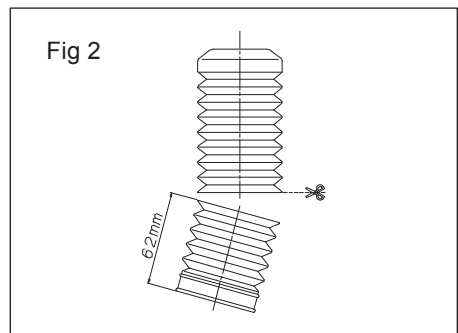
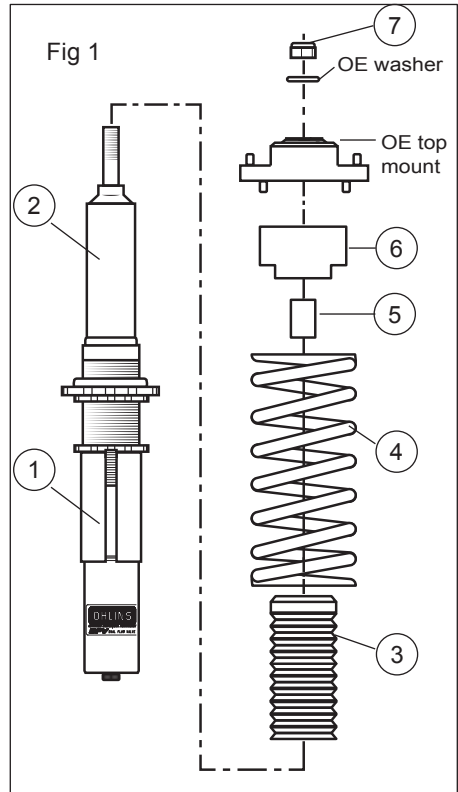

MOUNTING INSTRUCTIONS

6

Adjust the spring seat and the lock ring according to fig 5 and tighten to 50 - 60 Nm. Fit the sleeve (1), the dust boot (3), the spring (4), the spacer (5), the upper spring seat (6) the OE top mount, the OE washer and the M14 lock nut (7) to the strut according to fig 1. Tighten the lock nut to 35 - 40 Nm.

Note!

Remove the rubber spring isolator from the OE top mount according to fig 4.

Note!

When tightening the top mount nut, the shock absorber shaft must be held in position with a 6 mm Allen key.

7

Fasten the upper attachments to the vehicle.

8

Raise the wheel hub with a jack to remove the freeplay of the lower strut attachment bolts before tightening them.

Note!

Make sure that all bolts are tightened to the correct torque and that nothing fouls or restricts movement of the strut when it is being fully compressed or extended. Test this over the whole steering range from lock to lock.

9

Adjust the height adjuster lock ring according to fig 5 and tighten to 40 - 50 Nm.

10

Make sure that all removed parts are reinstalled in the same way as they were before the installation of the Öhlins shock absorber.

Note!

If the vehicle is equipped with OEM PASM shock absorbers, use Öhlins cancellation kit.

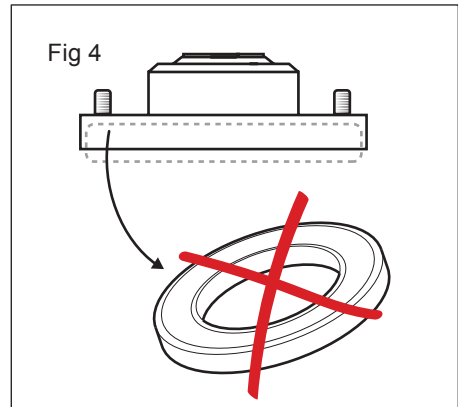
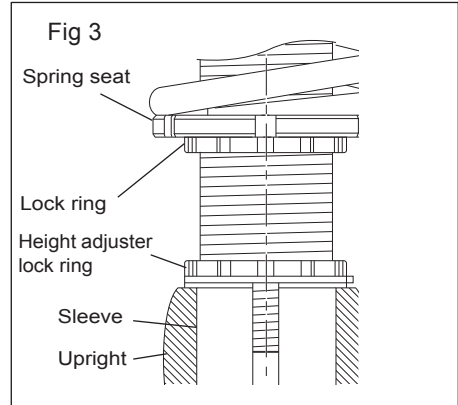

ADJUSTMENTS

⚠ Warning!

Before you ride/drive, always make sure that the setup is according to the recommended setup data. Read about adjustments and setting up in the Öhlins Owner's Manual before you make any adjustments. Contact an Öhlins dealer if you have any questions about setting up.

The preload is 2 mm from a free length of 200 mm, giving 198 mm installed length, see fig 5.

SETUP DATA

Recommended set-up

Rebound setting		
Track	2-7	clicks
Winding road	5-10	clicks
Street	10-20	clicks
Spring preload	2	mm
Shock absorber length	485	mm

Recommended spring

48010-19 (70 Nm/mm)

The actual vehicle height

With both the preload and height adjustments in their standard positions, the vehicle is lowered approximately 20 mm when compared to the original suspension. As the height adjuster is turned one rotation, the position moves 1.5 mm.

⚠ Warning!

The adjustment range is the standard position ± 15 mm.

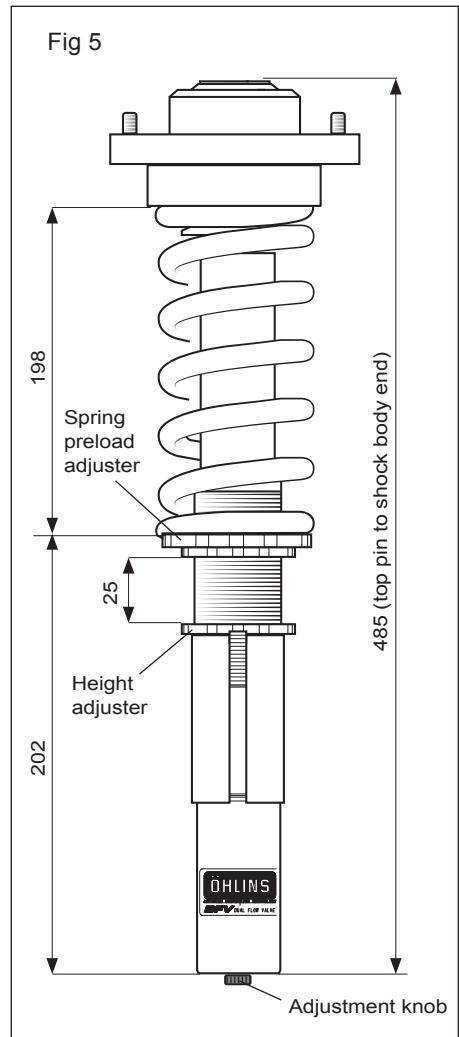

Öhlins products are subject to continuous improvement and development, therefore, although these instructions include the most up-to-date information available at the time of printing, minor updates may occur.

To find the latest information contact an Öhlins distributor. Please contact Öhlins if you have any questions regarding the contents in this document.

Part no. MI_POSMP80_0
Issued 2016-05-23

© Öhlins Racing AB. All rights reserved. Any reprinting or unauthorized use without the written permission of Öhlins Racing AB is prohibited.

Öhlins Racing AB
Box 722
S-194 27 Upplands Väsby, Sweden
Phone +46 8 590 025 00
fax +46 8 590 025 80



www.ohlins.com



Kit Contents

	Description	Part No	Pcs
1	Sleeve		2
2	Shock absorber	POS 6P80	2
3	Dust boot		2
4	Spring		2
5	Upper spring seat		2
6	Lock nut M14		2

👁 Note!

Please note that there can be small differences between your product and the images in these instructions.

👁 Note!

Please note that during storage and transport, especially at high ambient temperature, some of the oil and grease used for assembly may leak and stain the packaging. This will not cause damage to the product, wipe off the excessive oil or grease with a cloth.

👁 Note!

Before you install this product, check the kit contents. If anything is missing, please contact an Öhlins dealer.

⚠ Warning!

Before you install this product, read the Öhlins Owner's manual. This product is an important part of the vehicle and the vehicle stability.

Shock absorber Kit for Porsche 981 Cayman

POS MP80 rear

Mounting Instructions



MOUNTING INSTRUCTIONS

⚠ Warning!

We strongly recommend to let an Öhlins dealer install this product.

⚠ Warning!

If you work with a lifted vehicle, make sure that it is safely supported to prevent it from tipping over.

👁 Note!

When you work with this product, see the vehicle service manual for vehicle specific procedures and important data.

👁 Note!

Before you install this product clean the vehicle.

1

Raise the vehicle and put it on jack stands.

⚠ Warning!

Ensure that it is securely supported.

2

Remove the rear wheels.

3

Remove the lower and the upper attachments and remove the original shock absorbers.

4

Cut the dust boot 60 mm from the lower end with a pair of scissors according to fig 2.

5

Adjust the spring seat and the lock ring according to fig 4 and tighten to 50 - 60 Nm. Fit the sleeve (1), the dust boot (3), the spring (4), the upper spring seat (5) the OE washer, the OE top mount, the 2 pcs OE washers and the M14 lock nut (6) to the strut according to fig 1.

👉 Caution!

When tightening the top mount nut, the shock absorber shaft must be held in position with an Allen key.

Fig 1

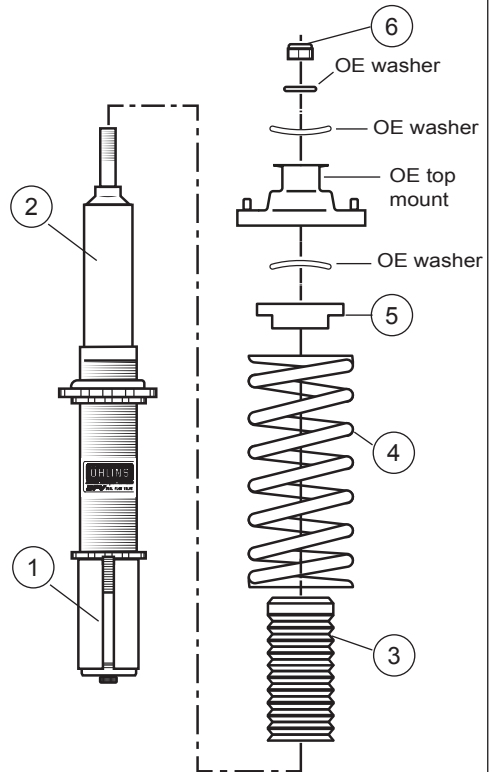
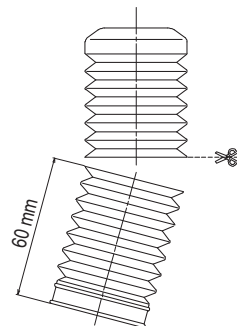

Fig 2



MOUNTING INSTRUCTIONS

6

Install the Öhlins shock absorbers on the vehicle and fasten the upper attachments.

7

Raise the wheel hub with a jack to remove the freeplay of the lower strut attachment bolts before tightening them.

8

Make sure that all removed parts are reinstalled in the same way as they were before the installation of the Öhlins shock absorber.

Note!

Make sure that all bolts are tightened to the correct torque and that nothing fouls or restricts movement of the shock absorber when it is being fully compressed or extended.

9

Tighten the height adjuster lock ring to 40 - 50 Nm according to fig 3.

Note!

If the vehicle is equipped with OEM PASM shock absorbers, use Öhlins cancellation kit.

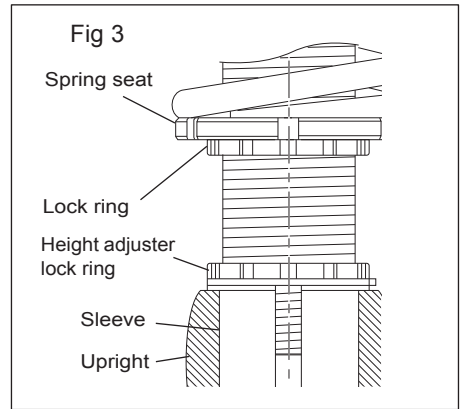

ADJUSTMENTS

⚠ Warning!

Before you ride/drive, always make sure that the setup is according to the recommended setup data. Read about adjustments and setting up in the Öhlins Owner's Manual before you make any adjustments. Contact an Öhlins dealer if you have any questions about setting up.

The preload is 2 mm from a free length of 200 mm, giving 198 mm installed length, see fig 4.

SETUP DATA

Recommended set-up

Rebound setting		
Track	2-7	clicks
Winding road	5-10	clicks
Street	10-20	clicks
Spring preload	2	mm
Shock absorber length	540	mm

Recommended spring

48010-23 (80 Nm/mm)

The actual vehicle height

With both the preload and height adjustments in their standard positions, the vehicle is lowered approximately 20 mm when compared to the original suspension. As the height adjuster is turned one rotation, the position moves 1.5 mm.

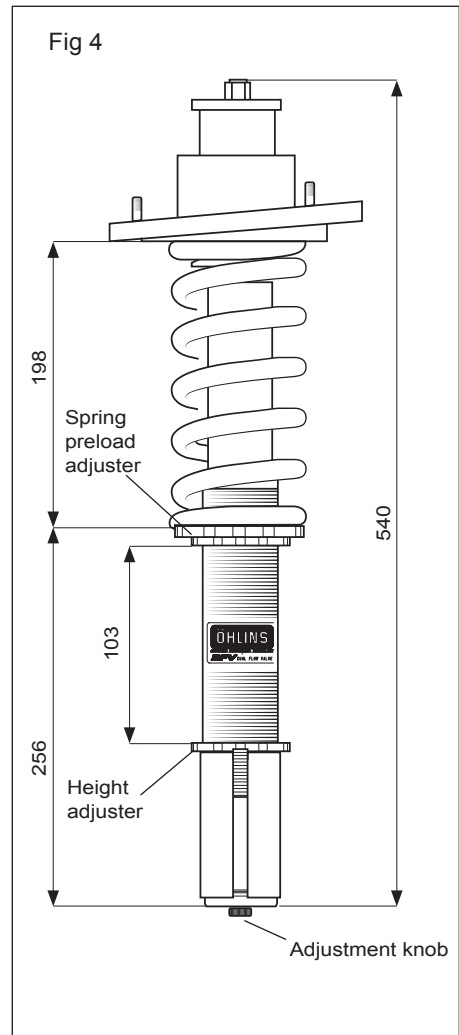

Öhlins products are subject to continuous improvement and development, therefore, although these instructions include the most up-to-date information available at the time of printing, minor updates may occur.

To find the latest information contact an Öhlins distributor. Please contact Öhlins if you have any questions regarding the contents in this document.

Part no. MI_POSMP80_0
Issued 2016-05-23

© Öhlins Racing AB. All rights reserved. Any reprinting or unauthorized use without the written permission of Öhlins Racing AB is prohibited.

Öhlins Racing AB
Box 722
S-194 27 Upplands Väsby, Sweden
Phone +46 8 590 025 00
fax +46 8 590 025 80



www.ohlins.com